

PNEUMATIC BALL VIBRATORS

MODEL K

- Aluminium Body
- Rotary Vibrator
- 2 Sets of mounting holes
- Frequency / Force adjustable by air pressure
- Suitable for temperature up to 100°C
- Force 130 N to 4050 N

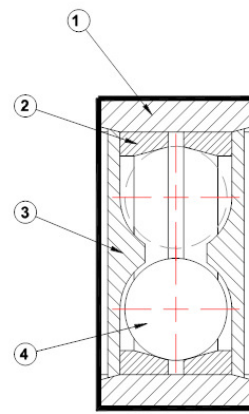
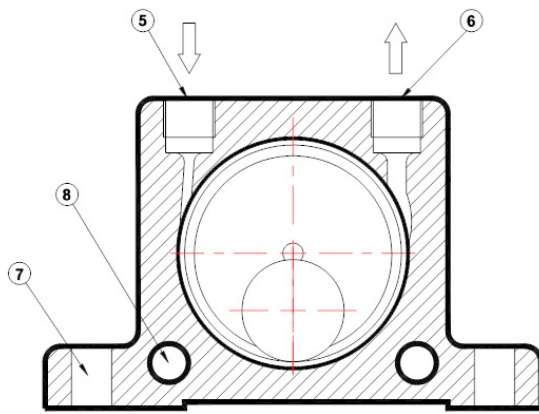

- 1. Extruded aluminium alloy body
- 2. Hardened ground steel alloy races
- 3. Nylon Endplates
- 4. Hardened lapped ball
- 5. Air Inlet
- 6. Air exhaust
- 7. Base mounting holes
- 8. Lateral Mounting

Standard Units K8 to K36 with nylon endplates
Max Temperature 100°C=212°F

Special Units K20HT to K36HT
Max Temperature 150°C=300°F

PERFORMANCE DATA

TYPE	Frequency V.P.M.			Centrifugal Force						Air Consumption / Minute					
	2 Bar 29 PSI	4 Bar 58 PSI	6 Bar 87 PSI	2 Bar N	29 PSI lbs	4 Bar N	58 PSI lbs	6 Bar N	87 PSI lbs	2 Bar litr	29 PSI CF	4 Bar litr	58 PSI CF	6 Bar litr	87 PSI CF
K8	25500	31000	35000	130	29	260	58	360	81	83	2.9	145	5.1	195	6.9
K10	22500	28000	34000	250	26	470	106	710	160	92	3.2	150	5.3	200	7.1
K13	15000	18000	22500	320	72	550	124	870	196	94	3.3	158	5.6	225	7.9
K16	13000	17000	19500	450	101	800	180	1100	248	122	4.3	200	7.1	280	9.9
K20	10500	14500	16000	720	162	1220	275	1720	387	130	4.6	230	8.1	340	12.0
K25	9200	12200	14000	930	209	1570	353	2050	461	160	5.6	290	10.2	425	15.0
K30	7800	9700	12500	1510	340	2470	556	3210	722	215	7.6	375	13.2	570	20.0
K36	7300	9000	10000	2060	464	3150	709	4050	911	260	9.2	475	16.8	675	24.0

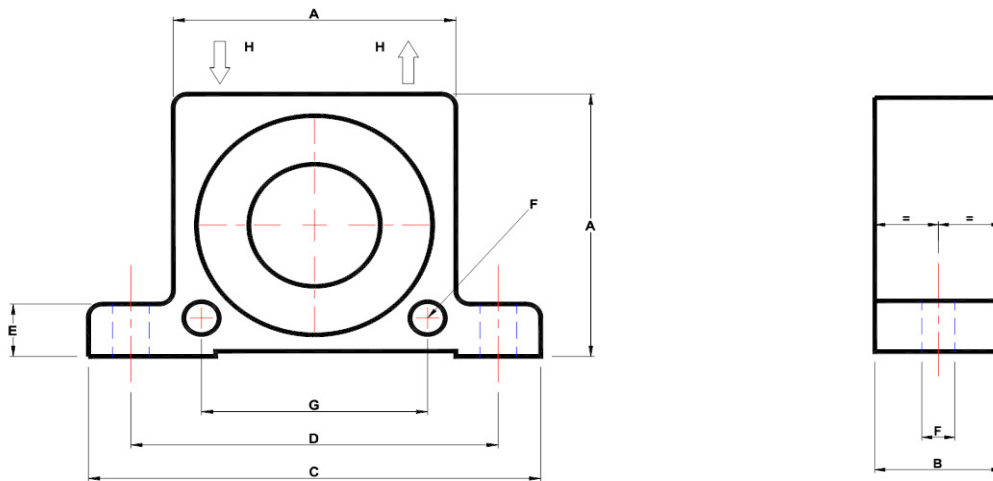

DIMENSIONS

TYPE	A		B		C		D		E		F		G		H BSP	Weight	
	mm	inch	mm	inch	mm	inch	mm	inch	mm	inch	mm	inch	mm	inch		kg	lbs
K8	50	1.97	20	0.79	86	3.38	68	2.68	12	0.47	7	0.27	40	1.57	1/4"	.130	.29
K10	50	1.97	20	0.79	86	3.38	68	2.68	12	0.47	7	0.27	40	1.57	1/4"	.130	.29
K13	65	2.56	24	0.94	113	4.45	90	3.54	16	0.63	9	0.35	50	1.97	1/4"	.230	.57
K16	65	2.56	27	1.06	113	4.45	90	3.54	16	0.63	9	0.35	50	1.97	1/4"	.300	.66
K20	80	3.15	33	1.30	128	5.04	104	4.09	16	0.63	9	0.35	60	2.36	1/4"	.530	1.17
K25	80	3.15	38	1.50	128	5.04	104	4.09	16	0.63	9	0.35	60	2.36	1/4"	.630	1.39
K30	100	3.94	44	1.73	160	6.30	130	5.12	20	0.79	11	0.43	80	3.15	3/8"	1.130	2.49
K36	100	3.94	50	1.97	160	6.30	130	5.12	20	0.79	11	0.43	80	3.15	3/8"	1.340	2.95

Data obtained on a heavy laboratory test block. Frequency and force will decrease on a less rigid mount.