

# Preparation unit—G Series

## GPR Series Precision Regulator



### Specification

Model	GPR20006	GPR30008	GPR40008	GPR40010	GPR40015
Fluid	Air				
Port size [Note1]	1/8"	1/4"	1/4"	3/8"	1/2"
Max. supply pressure	1.0MPa				
Operating pressure	Lower pressure	0.005~0.2MPa		0.01~0.2MPa	
	Medium pressure	0.01~0.4MPa			
	High pressure	0.01~0.8MPa			
Sensitivity	Within 0.2%F.S.				
Repeatability	Within ±0.5%F.S.				
Air consumption (ANR)	≤4L/min	≤4L/min	≤9.5L/min	≤11.5L/min	
Temperature range	-20~70°C(Unfreeze)				
Weight	144g	336g	717g		

[Note1] PT thread, G thread and NPT thread are available.

### Symbol



### Product feature

1. High pressure regulating accuracy and rapid-response;
2. Good pressure and flow chart;
3. Easy installation, it can be installed independently by bracket or directly with existing filter combination components of module type;
4. In addition to high pressure type, the type of medium pressure and lower pressure can be selected.

### Ordering code

GPR300 08 H □ □ G

① ② ③ ④ ⑤ ⑥

① Model	② Port size	③ Regulating pressure range	④ Accessories	⑤ Pressure gauge	⑥ Thread type [Note1]
GPR200: 200 Series Precision Regulator	06: 1/8"	L: 0.005~0.2MPa M: 0.01~0.4MPa H: 0.01~0.8MPa	Blank: Bracket J: No bracket	Blank: With pressure gauge N: Without pressure gauge	Blank: PT(Scale :MPa&psi) G: G(Scale:MPa&bar) T: NPT(Scale:bar&psi)
GPR300: 300 Series Precision Regulator	08: 1/4"	L: 0.01~0.2MPa M: 0.01~0.4MPa H: 0.01~0.8MPa			
GPR400: 400 Series Precision Regulator	08: 1/4" 10: 3/8" 15: 1/2"	L: 0.01~0.2MPa M: 0.01~0.4MPa H: 0.01~0.8MPa			

[Note1] Please consult us for special correspondence.

### Inner structure

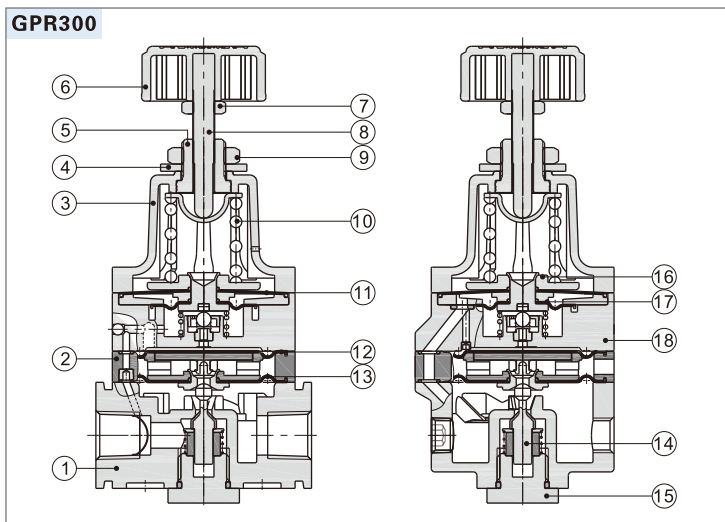

No.	Item	Material
1	Regulator body	Aluminum alloy
2	Pilot body	Plastic
3	Regulator seat	Aluminum alloy
4	Bracket gasket	SPCC
5	Adjusting nut	Carbon steel
6	Regulator knob	Plastic
7	Nut	Carbon steel
8	Regulator spindle	Carbon steel
9	Nut	Carbon steel
10	Spring	Spring steel
11	Pilot upper diaphragm	NBR
12	Regulator upper diaphragm	NBR
13	Regulator lower diaphragm	NBR
14	Main valve	Stainless steel+NBR
15	Bonnet	Carbon steel
16	Pilot diaphragm upper hard core	Aluminum alloy
17	Pilot lower diaphragm	NBR
18	Nozzle body	Aluminum alloy



## GPR Series Precision Regulator

### Pressure chart

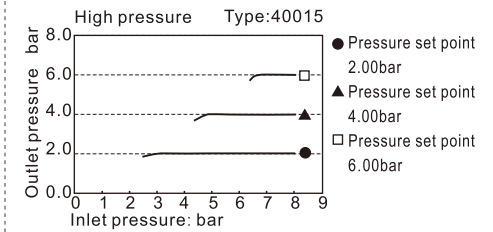
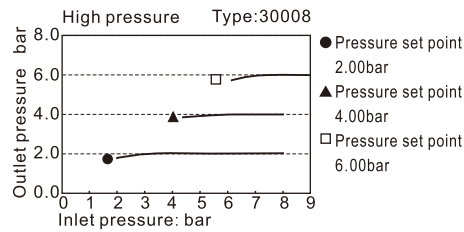
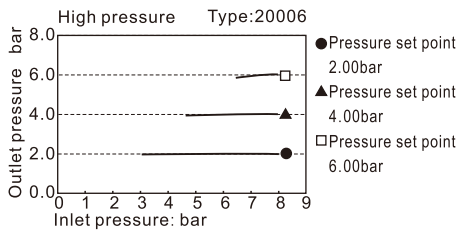
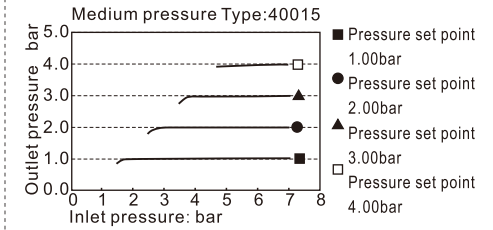
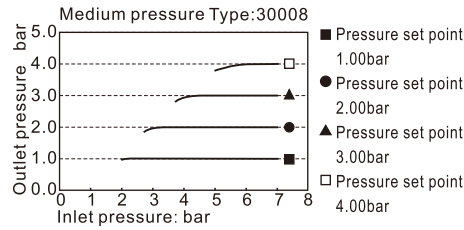
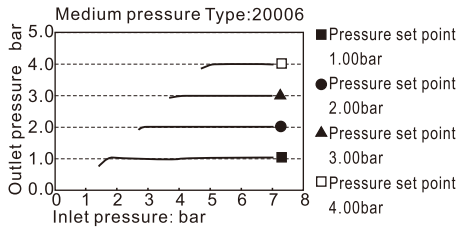
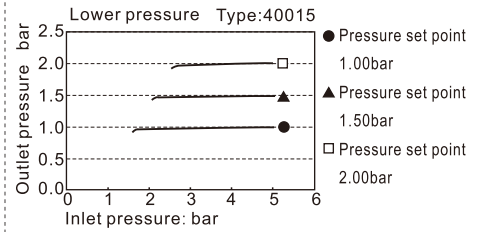
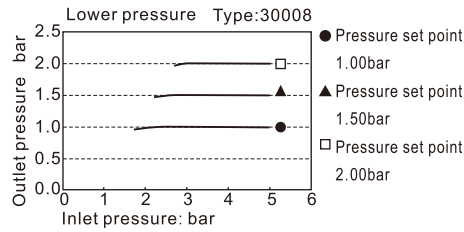
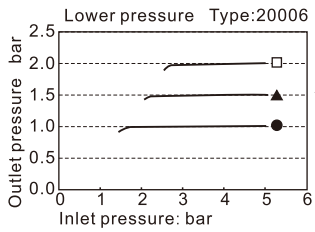

### Flow chart

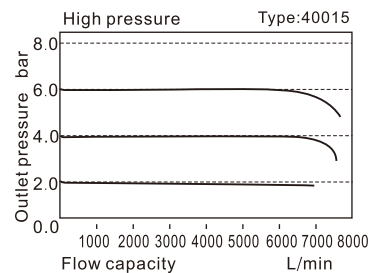
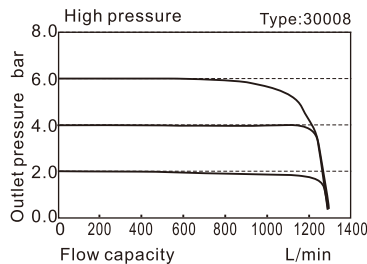
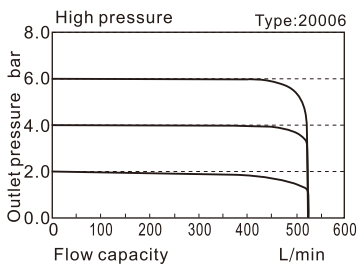
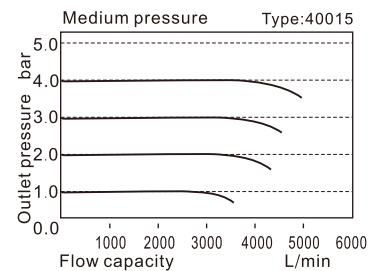
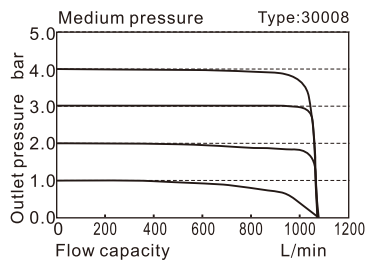
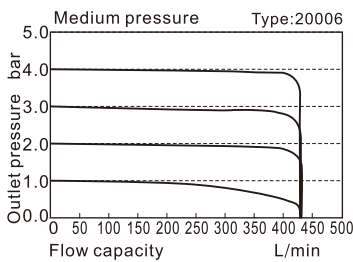
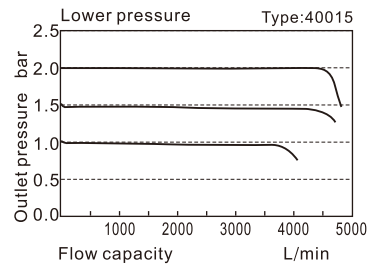
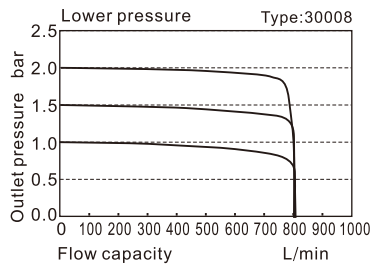
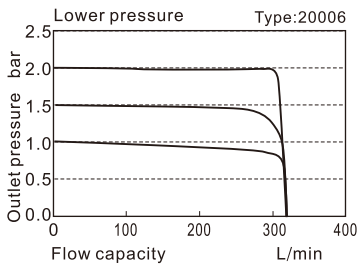

### Overflow chart

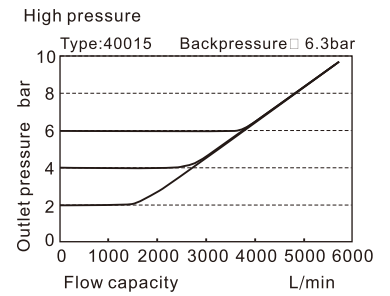
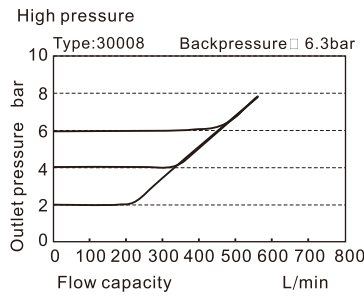
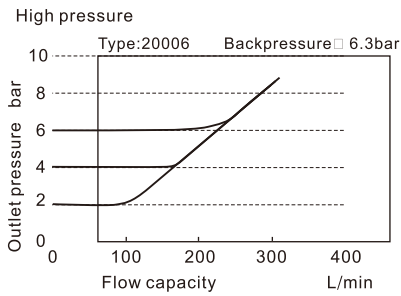
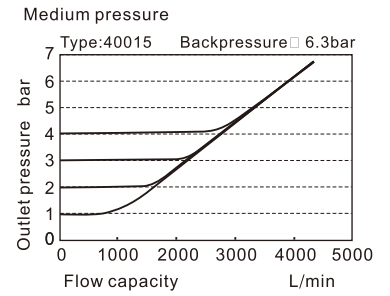
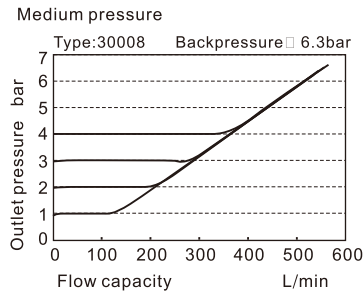
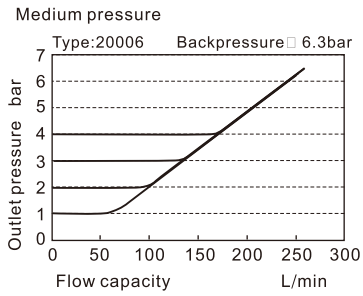
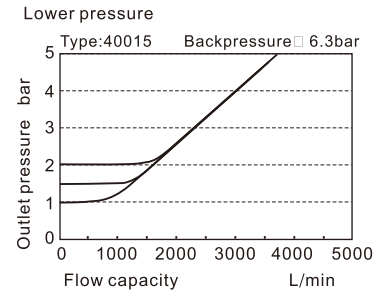
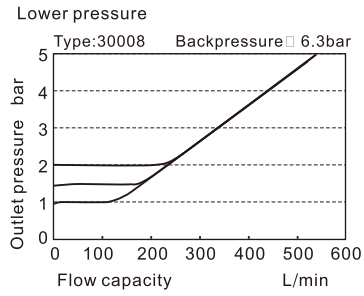
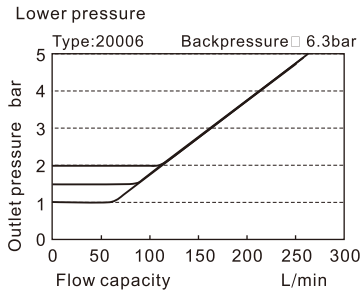

# Preparation unit — G Series

## GPR Series Precision Regulator

### Dimensions

#### GPR200

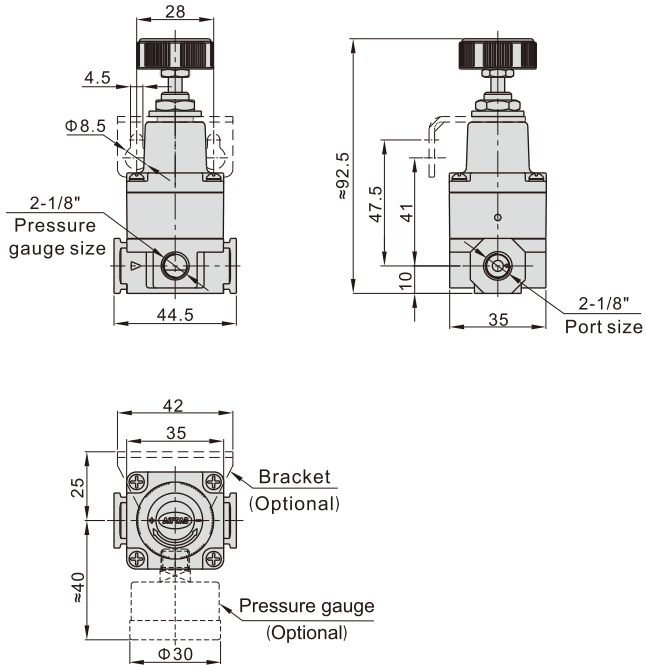

#### GPR300

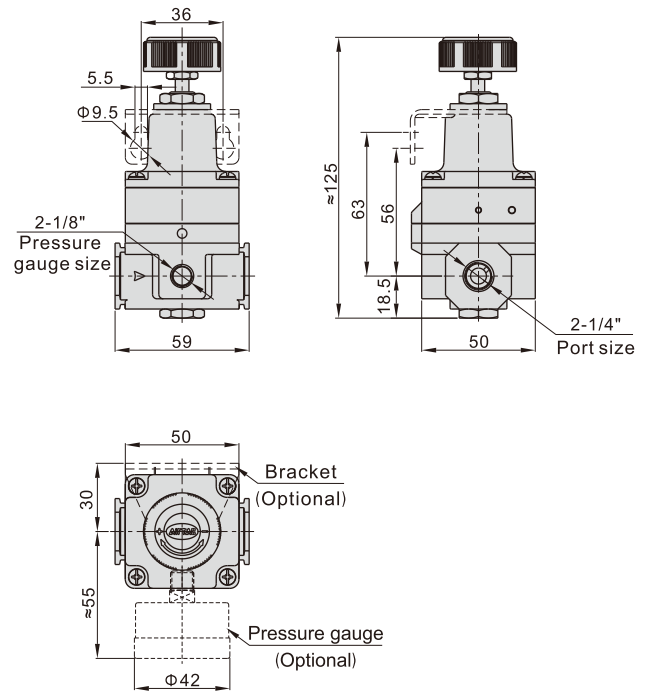

#### GPR400

